

Juniper.JN0-1332.by.KenDu.45q

Number: JN0-1332
Passing Score: 800
Time Limit: 120
File Version: 3.0

Exam Code: JN0-1332



Exam A

QUESTION 1

You are designing a high availability firewall solution. You select an off-path design instead of an inline design. What are two reasons for this decision? (Choose two.)

- A. The off-path design is less complex
- B. The off-path design is more flexible
- C. The off-path design uses fewer interfaces at the adjacency layer
- D. The off-path design requires a proper routing configuration for selecting traffic

Correct Answer: B

Section:

QUESTION 2

Your network design requires that you ensure privacy between WAN endpoints. Which transport technology requires an IPsec overlay to satisfy this requirement?

- A. L3VPN
- B. leased line
- C. internet
- D. L2VPN

Correct Answer: A

Section:

QUESTION 3

You are asked to implement Juniper AppSecure to increase application security. You want to analyze specific application usage. In this scenario, which AppSecure feature would accomplish this task?

- A. AppQoS
- B. AppTrack
- C. AppFW
- D. IDP/IP

Correct Answer: D

Section:

QUESTION 4

What are two considerations when performing a risk assessment for assets in a data center? (Choose two.)

- A. Insurance is a viable mitigation strategy when performing risk assessment calculations
- B. Exposure of assets could have larger economic impact than loss of assets
- C. Migration of a data center to a cloud provider increases economic impact of asset loss
- D. Migration of a data center to a cloud provider reduces the economic impact of asset exposure



Correct Answer: C

Section:

QUESTION 5

A new virus is sheading across the Internet, with the potential to affect your customer's network Which two statements describe how Policy Enforcer interacts with other devices to ensure that the network is protected in this scenario? (Choose two.)

- A. Policy Enforcer pulls security intelligence feeds from Juniper ATP Cloud to apply to SRX Series devices
- B. Policy Enforcer pulls security policies from Juniper ATP cloud and apples them to SRX Series devices
- C. Policy Enforcer automates the enrollment of SRX Series devices with Jumper ATP Cloud
- D. Security Director pulls security intelligence feeds from Juniper ATP Cloud and applies them to Policy Enforcer

Correct Answer: B

Section:

QUESTION 6

When designing the security for a service provider core router, you are asked to add a firewall fitter on the to0 interface in this scenario, which two protocols would you want to allow through the filter? (Choose two.)

- A. LLDP
- B. SSH
- C. BGP
- D. STP

Correct Answer: A, C

Section:

QUESTION 7

What are two reasons for using a cSRX instance over a vSRX instance? (Choose two)

- A. cSRX instances launch faster than vSRX instances
- B. cSRX instances share the host OS unlike vSRX instances.
- C. A cSRX instance uses more memory but uses less disk space than a vSRX instance
- D. A cSRX instance supports more features than a vSRX instance

Correct Answer: C

Section:

QUESTION 8

Refer the Exhibit.



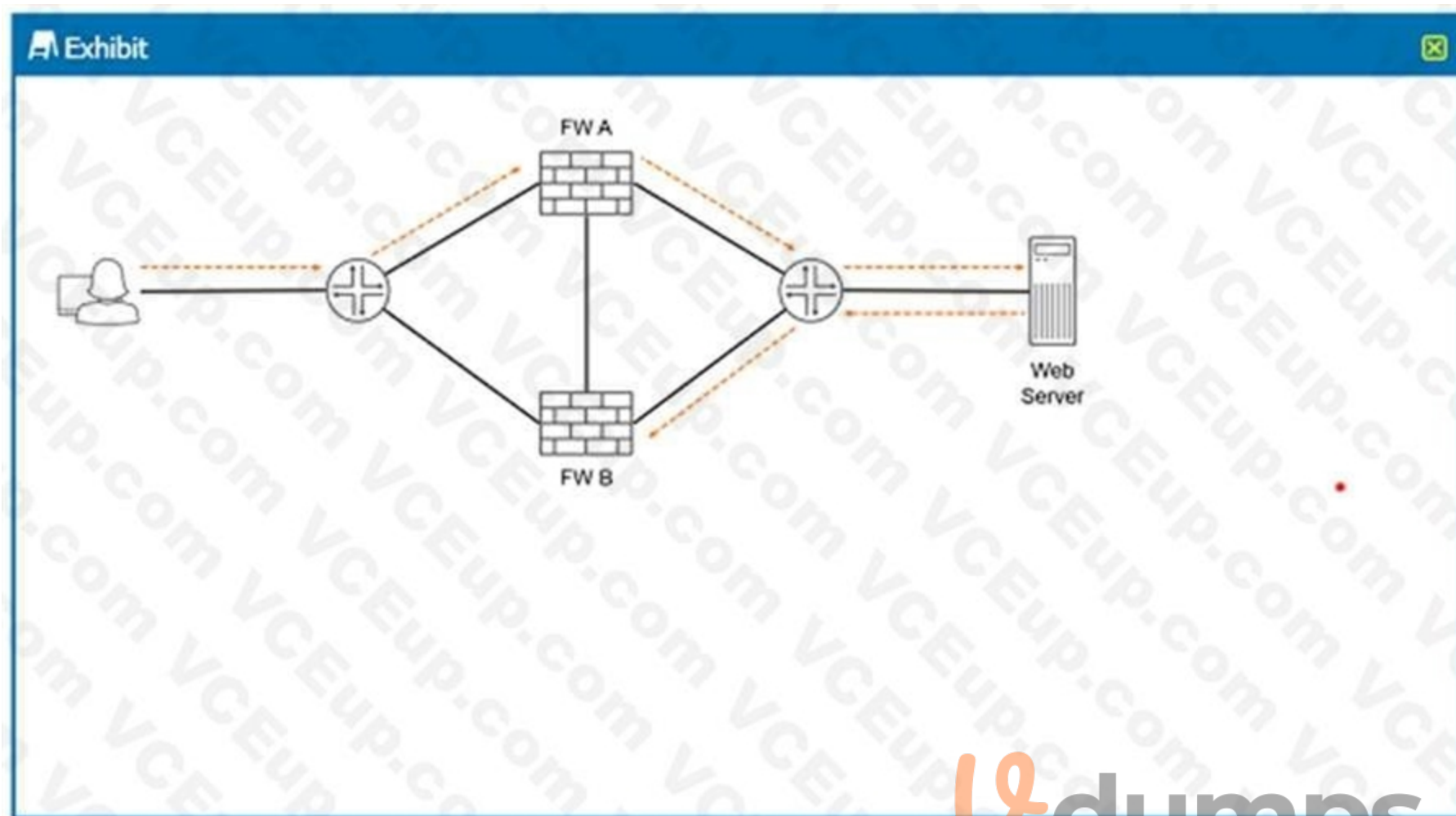

You must ensure that return Web traffic is not dropped by the firewall devices. What must be implemented on the link between FW A and FW B?

- A. VRRP
- B. session sync
- C. asymmetric routing
- D. BFO

Correct Answer: A

Section:

QUESTION 9

You are designing an IP camera solution for your warehouse. You must block command and control servers from communicating with the cameras. In this scenario, which two products would you need to include in your design?

(Choose two)

- A. SRX Series device
- B. Security Director
- C. Juniper ATP Cloud
- D. IPS

Correct Answer: C, D

Section:

QUESTION 10

Which firewall service is used as a first line of defense and often used by a security device to protect itself?

- A. intrusion prevention system
- B. unified Threat management
- C. network address translation
- D. stateless firewall filter

Correct Answer: A

Section:

QUESTION 11

You are asked to provide a design proposal to secure a service provider's network against IP spoofing. As part of your design, you must ensure that only traffic sourced from the same subnet is followed on the customer-facing interfaces.

Which solution will satisfy this requirement?

- A. BGP with source of origin community
- B. unicast RPF with strict mode
- C. unicast RPF with loose mode
- D. BGP labeled-unicast using the resolve-vpn option

Correct Answer: B

Section:

QUESTION 12

You are designing a central management solution. Your customer wants a logging solution that will support the collection of up to 10,000 events per second from many SRX Series devices that will be deployed in their network. In this scenario, which solution should you include in your design proposal?

- A. Log Collector
- B. Network Director
- C. Contrail Insights
- D. Contrail Server Orchestration

Correct Answer: A

Section:

QUESTION 13

You want to reduce the possibility of your data center's server becoming an unwilling participant in a DDoS attack. Which features should you use on your SRX Series devices to satisfy this requirement? (Choose two.)

- A. dynamic IPsec tunnels
- B. Juniper ATP Cloud GeolIP
- C. UTM Web filtering
- D. Juniper ATP Cloud CC feeds

Correct Answer: A, D

Section:



QUESTION 14

Refer to the exhibit.

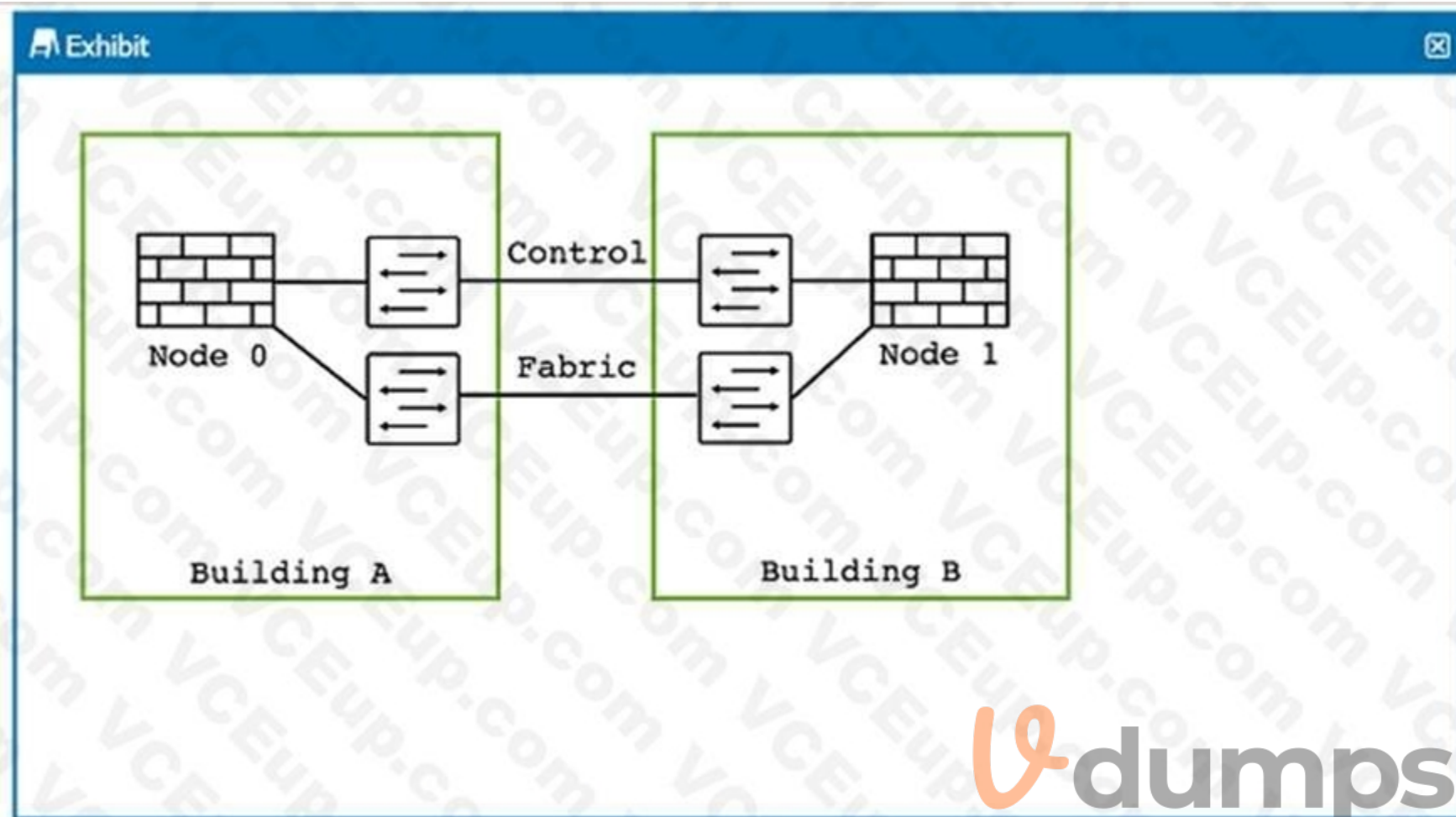

You are designing a security solution using an SRX Series chassis cluster in two separate buildings. In this scenario, what are three considerations? (Choose three.)

- A. The switches connecting to interface fab1 must support jumbo frames
- B. Latency on the fabric path must be under 1000 ms
- C. Latency on the control path must be under 100 ms
- D. The switches connecting to interface fxp: must support jumbo frames
- E. Both HA links must be on physically different switches.

Correct Answer: A, C, D

Section:

QUESTION 15

As part of your service provider WAN network design, you are asked to create a design that secures BGP communication. In this scenario, what are two reasons you would choose BGP Generated TTL Security Mechanism (GTSM)? (Choose two.)

- A. You have an automated method of rotating MD5 hashes on each router.
- B. All of your router BGP connections are point-to-multipoint.
- C. All of your router BGP connections are point-to-point
- D. You do not have an easy method of rotating MD5 hashes on each router

Correct Answer: B, D

Section:

QUESTION 16

Which two statements describe Juniper ATP Cloud? (Choose two)

- A. Juniper ATP Cloud can use a sandbox to detect threats that use evasion techniques.
- B. Juniper ATP Cloud runs mime with network traffic to Nock all traffic before reaching endpoint.
- C. Juniper ATP Cloud provides protection against zero-day threats
- D. Juniper ATP Cloud is an added app that must be instated with Security Director

Correct Answer: A, D

Section:

QUESTION 17

When two security services process a packet whether it is being processed in the first-packet path or the fast path? (Choose two.)

- A. screen options
- B. ALG
- C. route lookup
- D. policy lookup

Correct Answer: C, D

Section:

QUESTION 18

Physical security devices are "blind" to which type of traffic?

- A. bare metal server to VM
- B. private VLAN
- C. intra-server traffic
- D. management

Correct Answer: B

Section:

QUESTION 19

Which two steps should be included in your security design process? (Choose two)

- A. Define an overall routing strategy
- B. identity external attackers
- C. Identify permitted communications
- D. Identify security requirements for the customer's organization

Correct Answer: B, C

Section:

QUESTION 20



Exhibit.

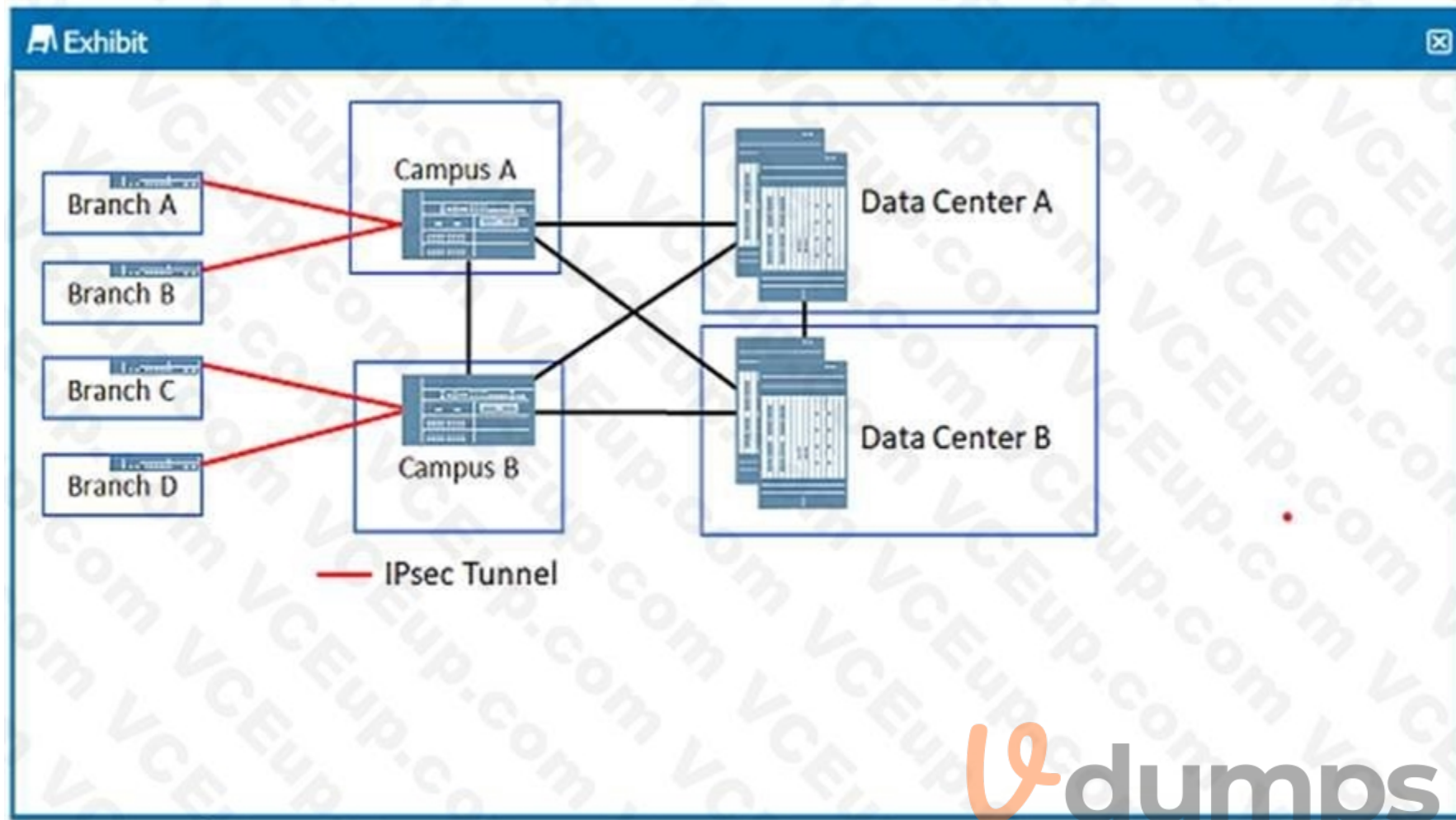

In the 3-tier VPN design shown in the exhibit, which function are the Campus A and Campus B SRX Series devices performing?

- A. Internet security gateway
- B. data center firewall
- C. WAN aggregation
- D. VPN bridging

Correct Answer: A

Section:

QUESTION 21

You are designing a security solution for an existing data center. All traffic must be secured using SRX Series devices, however, you are unable to change the existing IP addressing scheme. Which firewall deployment method satisfies this requirement?

- A. transparent deployment
- B. two-arm deployment
- C. one-arm deployment
- D. inline deployment

Correct Answer: A

Section:

QUESTION 22

Refer to the Exhibit.

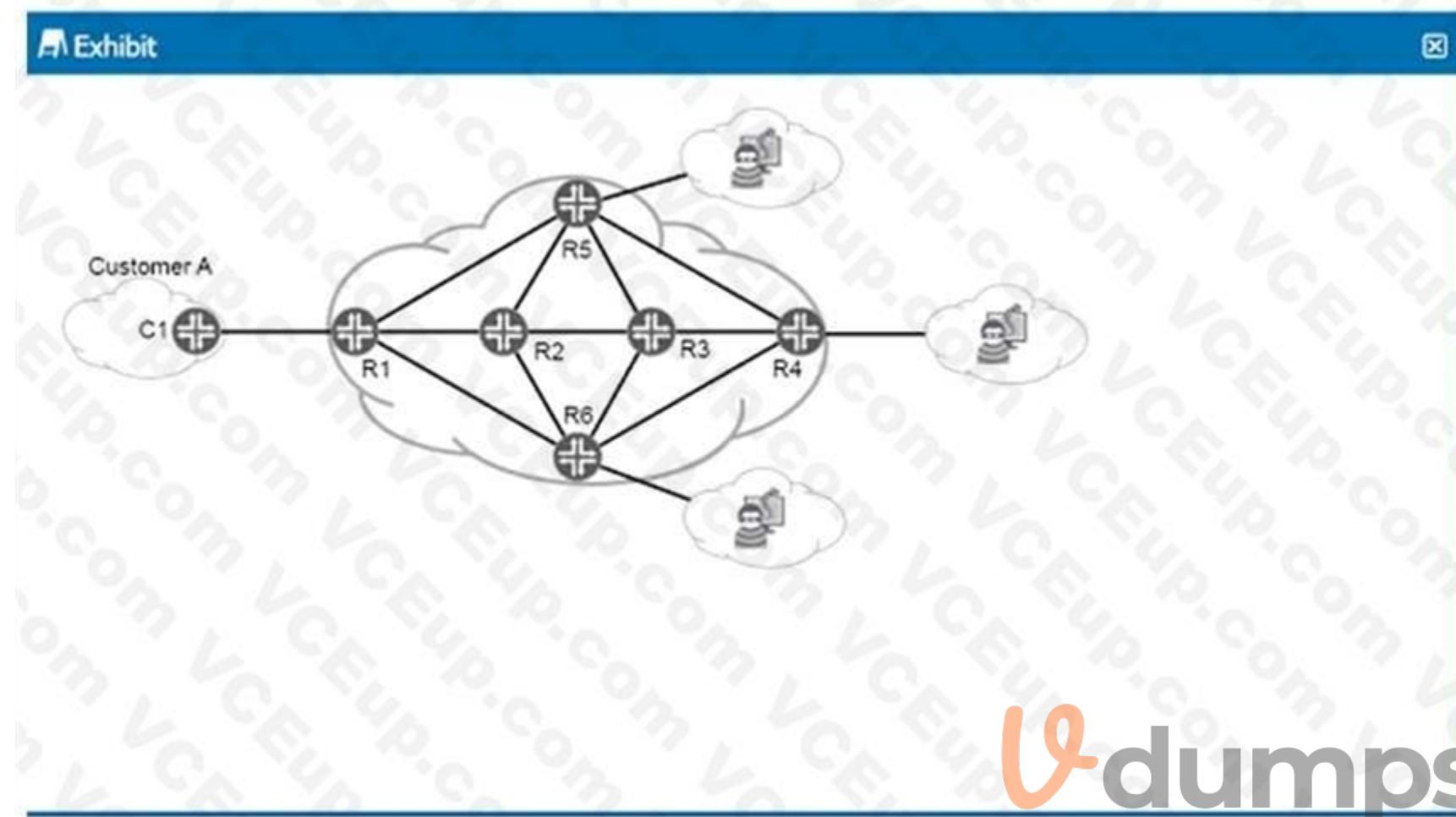

You are asked to provide a proposal for security elements in the service provider network shown in the exhibit. You must provide DDoS protection for Customer A from potential upstream attackers. Which statements correct in this scenario?

- A. You should implement DDoS protection to drop offending traffic on the edge devices closest to the destination of the attack.
- B. You should implement DDoS protection to drop offending traffic on the edge devices closest to the source of the attack.
- C. You should implement DDoS protection to drop offending traffic on the core devices.
- D. You should implement DDoS protection to drop offending traffic on the customer edge device.

Correct Answer: C

Section:

QUESTION 23

You must implement a security solution that uses a central database to authenticate devices without EAP-M05 based on their network interface address. Which solution will accomplish this task'?

- A. static MAC bypass
- B. MAC RADIUS
- C. 802.1X single secure
- D. 802.1X multiple

Correct Answer: C

Section:

QUESTION 24

You are asked to design an automated vulnerability scanner that can actively check to see which ports are open and report on the findings. Which Juniper Networks product would you use in this scenario?

- A. Security Director
- B. Log Director
- C. Policy Enforcer
- D. JSA

Correct Answer: C

Section:

QUESTION 25

When using Contrail networking, security policies are distributed as access control list to which component?

- A. vSwitch
- B. vSRX
- C. vMX
- D. vRouter

Correct Answer: D

Section:

QUESTION 26

Which automation language would you use to create on-box and off-box scripts for SRX Series devices?

- A. Python
- B. Perl
- C. Java
- D. Ruby

Correct Answer: D

Section:

QUESTION 27

When designing security for the service provider WAN, you are asked to implement unicast reverse path forwarding (uRPF) in this scenario. On which interfaces would you choose to implement loose mode uRPF?

- A. On interfaces where the best forwarding path for routes is through the receiving interface
- B. On interfaces that are user access interfaces
- C. On interfaces where all data originates on the same network as that of the router interface
- D. On interfaces that participate in multihomed environments

Correct Answer: B

Section:

QUESTION 28

You are asked to enable denial of service protection for a webserver behind an SRX Series device. In this scenario, which feature would you enable?

- A. screens
- B. App Secure
- C. Web filtering
- D. Juniper ATP

Correct Answer: D
Section:

QUESTION 29

As part of a design requirement you are asked to allow users in a specific department to authenticate only on their laptops and no other devices on the same network port. Which mode of 802 .1X authentication will you use to satisfy this requirement?

- A. multiple
- B. single-secure
- C. single
- D. MAC RADIUS

Correct Answer: A
Section:

QUESTION 30

You must design a separate network within your trust network with added security and separation. What is the common name for this type of network?

- A. guest
- B. DMZ
- C. enclave
- D. trust

Correct Answer: C
Section:

QUESTION 31

Which solution would you deploy to accomplish this task?

- A. Junos Space Log Director
- B. Juniper Networks Central insights
- C. Junos Space Security Director
- D. Juniper Networks Secure Analytics

Correct Answer: A
Section:

QUESTION 32

You must ensure that all 10GbE interfaces have an MTU of 9192 and that an of the ge-0/0>4.0 interfaces on the SRX Series devices are in a specific zone. Which type of a script would you use to accomplish this task?



- A. REST script
- B. commit script
- C. event script
- D. op script

Correct Answer: D

Section:

QUESTION 33

You are asked to provide a network design proposal for a service provider. As part of this design you must provide a solution that allows the service provider to mitigate DDoS attacks on their customers. Which two features will satisfy this requirement? (Choose two)

- A. 8GP traffic engineering
- B. 8GP FlowSpec
- C. remote triggered Hack hole (RTBH)
- D. Storm control

Correct Answer: C

Section:

QUESTION 34

What are two characteristics of an overlay network design? (Choose two.)

- A. The overlay network contains per-tenant state
- B. The overlay network uses tunnels to transfer traffic.
- C. The physical network contains per-tenant state.
- D. The physical network uses tunnels to transfer traffic

Correct Answer: A

Section:

QUESTION 35

Refer to the exhibit.



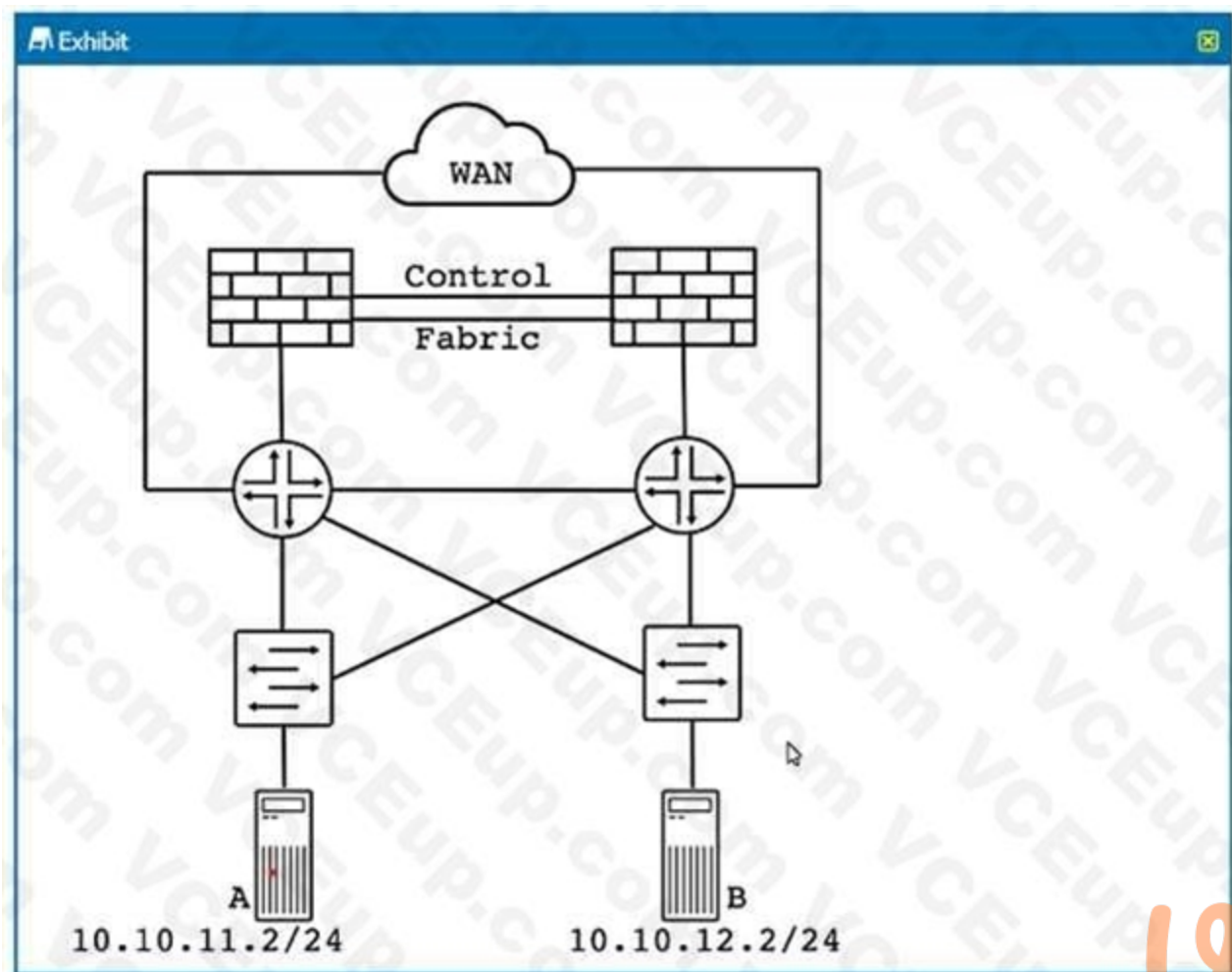

The SRX Series devices are deployed in an off-path active/passive Cluster configuration. What are two advantages of this deployment model over an active-active cluster configuration? (Choose two)

- A. load-balancing of east/west traffic
- B. load-balancing of north/south traffic
- C. reduced latency
- D. reduced fabric link traffic

Correct Answer: C, D

Section:

QUESTION 36

You are asked to deploy multiple kiosk locations around the country. Their locations will change frequently and will need to access services in the corporate data center as well as other kiosk locations. You need a central key location. In this scenario, which solution would you deploy?

- A. Mesh VPN
- B. Group VPN
- C. Juniper Secure Connect
- D. Auto VPN

Correct Answer: D

Section:

QUESTION 37

Which two statements are true about WAN security considerations? (Choose two.)

- A. MACsec increases protection on all WAN types
- B. Provider VPN circuit require IPsec
- C. internal connections are susceptible to fragmentation
- D. IPsec increases protection on all WAN types

Correct Answer: C

Section:

QUESTION 38

You are designing a security solution that includes SRX Series firewalls in a chassis cluster. In this scenario, which two elements must be part of the design? (Choose two.)

- A. The physical interface on each SRX Series device making up the reth interface must be in the same L2 domain
- B. The physical interface on each SRX Series device making up the reth interface must be in separate L2 domains
- C. The cluster ID must be the same on both SRX Series devices
- D. The node ID must be the same on both SRX Series devices

Correct Answer: B

Section:

QUESTION 39

You are designing Enterprise WAN attachments and want to follow Juniper recommended security practices. In this scenario, which two statements are correct? (Choose two.)

- A. Authentication authorization and accounting should be implemented on network resources
- B. The branch CPE should be configured to all outbound traffic
- C. Printer traffic should be segmented from data traffic.
- D. Network management traffic should be segmented from data traffic

Correct Answer: A, D

Section:

QUESTION 40

You are asked to segment the networks connected to an SRX Series device into distinct logical groups with different security requirements. How would you accomplish this task?

- A. Define different NAT policies for each network segment.
- B. Define different security policies for each network segment.
- C. Define different intrusion prevention policies for each network segment.
- D. Define different security zones for each network segment

Correct Answer: B

Section:

QUESTION 41

What are two factors you must consider when designing a network for security intelligence? (Choose two.)

- A. the number and model of JSA Series devices
- B. the third-party management application
- C. the number and model of SRX Series devices
- D. the Junos OS version

Correct Answer: B

Section:

QUESTION 42

Multiple customers use the shared infrastructure of your data center. These customers require isolation for compliance and security reasons.

What would you do to satisfy this requirement?

- A. Isolate each customer by using different physical hard//are
- B. Deploy multiple physical security control points
- C. Deploy a single logical security control point.
- D. Place each customers VLANs separate virtual router

Correct Answer: C

Section:

QUESTION 43

You are a security architect for a small managed service provider. The marketing team has proposed providing firewall services to the customers.

The requirements for the solution are shown below

- The customer must be able to manage their own security device.
- You must provide segmentation using Layer 2 and Layer 3.
- You need to implement dynamic routing
- You need to provide UTM services in this scenario. which product would you select to provide the firewall services?

- A. cSRX
- B. vSRX
- C. vMX
- D. vQFX

Correct Answer: D

Section:

QUESTION 44

When considering data center security, which aspect represents the weakest link?

- A. IPS signatures
- B. application software bugs
- C. firewall performance
- D. people

Correct Answer: A

Section:

QUESTION 45

When considering the data center, which two security aspects must be considered? (Choose two)

- A. theoretical
- B. conceptual
- C. physical
- D. logical

Correct Answer: A

Section:

